Tablet hardness tester

YD-1

User's Manual

Table of Contents	1
Table of Contents	1
Introduction	2
Product registration	2
Technical service	2
Proper operation	2
Contact Us	2
Introduction	3
Brief introduction	3
Function description	3
Specification	4
Environment requirement	4
Power supply	5
Installation	5
Check	5
Instrument settle	5
Connect to the power supply	5
Offset adjustment	5
Zero hardness adjuster	5
Hardness value is rectified	5
Operation	6
Power on	6
Test	6
Power off	6
Demonstration	6
Maintenance	6
Troubleshooting	7
Packing list	8
Product quality guarantee	8
Using instruction	9
Registration card	9

Introduction

Thanks for purchasing the product YD-1 Tablet hardness tester designed and manufactured by us.

Please read user's manual carefully before using the product. It will help you operate it properly and efficiently.

Product Registration

Prior to use the product, please fill up the user's registration card and mail to us, in order to get our service in future.

Technical Service

Pls. contact our marketing department for any service during warranty. Be sure that you have sent back the user's registration card.

If you have any problems, Pls. Try to find answers in user's manual first, or you can call our marketing department.

Proper Operation

Make sure you have read this manual carefully before installing/operating the instrument. For any concerns pls. Contact us.

- Transport with care. Any incline, convert, and hit are prohibited.
- Check and protect all safety related labels.
- It is prohibited to use any damaged product and power cord.
- Turn off the power before maintenance, or moving.

Contact Us

Introduction

Brief introduction

YD-1 Tablet hardness tester consist of main box, control system, sensor, transmission part, probe part, printer etc. and centrally controlled by precision auto-control system consisted by micro-P. It has features of high-auto-operation, simplified control, and convenience for operation, high accuracy, high sensitivity, concision style and lower noise.

YD-1 Tablet hardness tester consist of bottom, main box, front panel, rear panel etc.

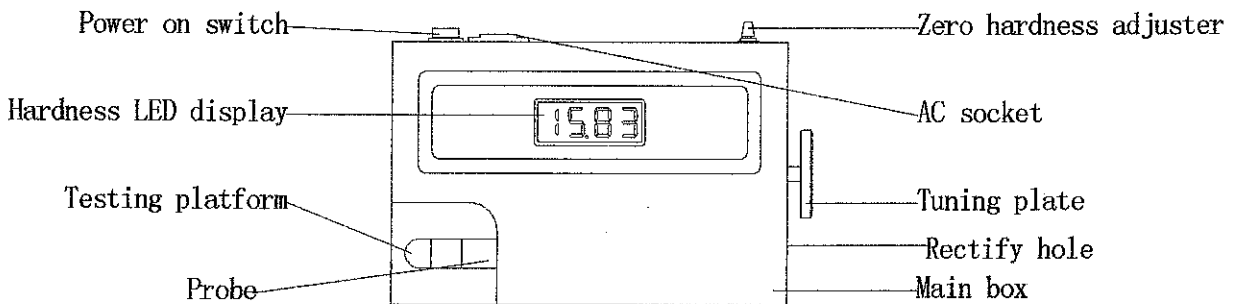

Front panel includes:

- Hardness LED display
- Product
- Manufacturing Test

Rear panel includes:

- Power on switch
- AC socket(fuse jack included)
- Zero hardness adjuster
- Name plate

Function description

- Hardness LED display

4 digital LED display hardness value of test, unit is N.

- Zero hardness adjuster

Zero adjuster, to offset hardness value to zero. Turn adjuster clockwise, the value is up, otherwise the value is down.

- Power on switch

Power on switch is main power switch, in on position, tester is in stand by status, OFF position, tester stop working.

Before connecting to AC power, please ensure it's in OFF position!

● AC socket

Ac socket is connected to the power supply with power cord offered in this tester.

Fuse is under the ac socket, attached one 1A fuse and backup one is offered. This is to prevent damage to this tester in suddenness case happened.

Please make sure ac power supply is connected properly!

When change fuse, make sure same spec part is used for tester safety!

● Transmission Parts

Transmission Parts are made up of tuning plate, transmission devices and etc. used for squeezing the tablets. Turn the transmission plate counterclockwise the probe goes to left and the squeezing force increase; turn the plate clockwise, the probe goes right and the squeezing force decreases.

● Probe Parts

Probe parts are made up of probe and testing platform. The probe is connected to the sensor and the testing platform is used for holding the tablets. Be extraordinary careful and make sure the force applied on the probe is no more than 196N.

Specification

Hardness range:	<u>2 ~ 199.9 N</u>
Hardness accuracy:	± 0.5 N
Moving distance of probe:	20 mm
Continues working time:	> 24 h r
Power:	220 V / 50 Hz / 10 W
Dimension:	320 × 180 × 100 MM ³
Weight:	5 KG

Environment requirement

Usage temperature	+18 °C ~ +28 °C
Store temperature	-10 °C ~ +50 °C
Humidity	20 % ~ 80 %

Power supply

Range of input power supply	220 V ± 10 % V A C	50 H z
Max input power		10 W

Installation

Checking

Open package, take out manual, tester, and accessories, and check items per packing list, any mismatch/damage happened, please contact marketing department immediately.

Tester settle

Tester must be placed in stable work station/ table and put damping pad between table and tester.

Clean tester periodically to prevent dusty affect normal operation.

Connect to the power supply

Link the socket & ac power supply source with attached power cord.

Offset adjustment

Zero hardness adjustment

Ajuste del cero

Turn on the instrument and pre-heat the machine for about 20 minutes. Adjust the Zero hardness adjuster till the number in the hardness LED display is 000.0. Turn the hardness adjuster clockwise the number displayed increases. Turn the hardness adjuster counterclockwise the number decreases.

Hardness value is rectified

Calibración

- ① Tear the circular grey membrane on rear board, show hardness value rectify-regulator.
- ② Install weight hook to the rectify hole in machine left side.
- ③ Erect the tester left on the table and support with hands, make the weight hook outside table.
- ④ Power on the tester, adjust the zero-regulator on the rear panel to make the hardness displayed 000.0N.
- ⑤ Load standard weights 10KG on the hook and it must display 98N (±0.5N). Don't over load please.
- ⑥ If display were wrong, adjust the rectify-regulator to make the hardness displayed 098.0N (±0.5N).
- ⑦ Remove the 10KG weights and adjust the zero-regulator to make the hardness

displayed 000.0N.

- ⑧ Repeat steps⑥—⑦ until the hardness displayed 000.0N when unload and 098.0N.
- ⑨ unload the weight hook, paste the circular grey membrane on the rectify-regulator.

Operation

Uso

Power on

Encendido

Turn the power switch to ON position, the indicator light, initialize the tester for 20 minutes, then it's readiness.

Pre-heated for 20 minute, the system is at the initial state. The system should be adjusted to display 000.0 in hardness indicator if necessary. 20 more minutes later the system is at testing state with a sound of beeping and ready for testing.

Test

Testeo

Turn the tuning plate clockwise and move the probe right to proper position. Put the tablet to be tested on the testing platform and turn the tuning plate counterclockwise carefully. The number displayed on the hardness indicator increases along with the probe squeezing the tablet. The number on hardness indicator reaches the biggest at the time the tablet is to be broken. The system will lock the number and beep sounds, the number on the LED indicator is the hardness of the sample. About 10 seconds later, the beeper stops sounding and the system is ready for the next test.

Power off

Apagado

Turn switch to OFF position, the indicator is off, tester stop.

Demonstration

- ① Power on and preheat the tester.
- ② Zero adjustment.
- ③ Place the tablet on the test plate, begin test.
- ④ Read the hardness.
- ⑤ Same with above portion repeat 2-4 steps.
- ⑥ Turn off the tester after test completed.

Maintenance

Mantenimiento / limpieza

Must clean box and parts periodically, do not use steel brush, it result in damage to the tester.

After testing every time, pls. Clean rotation parts and ensure dry to avoid

damage to the tester.

Troubleshooting

- Can not power on

Check whether the voltage is OK and fuse is OK, please refer to the rating marked in nameplate while installation.

If the tester does not work after checking above items, please don't repair it by yourself, contact our market department please.

Packing list

The YD-1 Tablet hardness tester include following items typically:

- Tester ————— 1
- 220V AC power cord ————— 1
- Brush ————— 1
- hook ————— 1
- User's manual ————— 1
- Product quality guarantee ————— 1
- User registration card ————— 1

Product quality guarantee

- This quality guarantee covers the scope of YD-1 Tablet hardness tester.
- Start from purchasing date; warranty period is one year.
- This quality guarantee is effective from receiving registration card filled by users.
- During warranty, we offer free charge service for troubleshooting in normal cases, but for any cases caused by flood, fire, earthquake, or other calamity, is excepted.
- During warranty, in one of the following cases, we will charge for material/service:
 - No product quality guarantee, mismatch with this guaranty or wrong record/remark.
 - Damages caused by unusual working environment.
 - Damages caused by disassembly, install, extend, move or modify without our permission.
 - Damages caused by repairing without our permission.
 - Damages sensor caused by overloading or struck.
- Keep this guarantee in proper place and any other issue is provided.
- The guarantee is only applicable in Chinese mainland.

Using Instruction

- Proper operation & maintenance will prolong the working time of the instrument. Please follow the manual's instruction carefully.
- When the power supply is unstable, pls. Use AV regulator. Pay special attentions to the information related to power supply, temperature, humidity in the manual.
- Always keep the instrument cleaning. Disassembly/move any parts of the tester is prohibited.
- In case of trouble present, pls. Stop using, call us or dealer for help.

Registration card

Name	_____	
Address	_____	
ZIP	E-mail	_____
Tel	Fax	_____
Product	_____	
Model	S/N	_____